

ROLL-BED PRESS

H Frame
80-200 Ton Presses

Heavy-Duty Straightening Fixtures



No. SF50 – Fixtures for use with 80-ton Roll-Bed® presses or 50-ton heavy-duty shop presses. (2 ea.). Wt. 104 lbs. **Not part of press, order separately.**

No. SF150 – Fixtures for use with 100-, 150- and 200-ton Roll-Bed® presses and 100-ton shop presses only (1 pr.). Wt. 196 lbs. **Not part of press, order separately.**



- The original, patented Roll-Bed design. Bed rolls out for easy loading and unloading with a crane or other lifting device.
- Movable work head glides easily side to-side for full off-center load capacity across width of upper frame.
- “Daylight” is 1283 x 1524mm for 80- and 100-ton models; 1302 x 1625mm on 150- and 200-ton presses.
- Fast approach of double-acting, 334mm stroke cylinder is provided by electric/hydraulic pump with remote control hand switch. Operator can view work from all sides with fingertip control of cylinder piston travel.
- **Adjustable lower bed width** – For secure balancing and centering of heavy jobs. Loosen adjusting bolts to adjust bed from 102mm to more than 686mm. See dimension “H.”
- **Movable work head** – For off-center pressing jobs, work head moves on bearings across upper bolster. Presses can be used at full capacity, regardless of where work head is placed.
- **Lifting mechanism** – Simply turn crank handle to raise or lower upper bolster. Screw mechanism raises or lowers both sides evenly (a heavy duty 1/2" drill motor can replace handle for automatic adjustment). Four locking pins hold bolster in place for pressing.

PRESS FEATURES:

- **Roll-Bed design** – Bed glides in or out on bearings to make loading and unloading fast and easy.

Optional heavy-duty straightening fixtures – Make straightening jobs easy and accurate to within .01mm! Rollers are ball bearing mounted and handle raises or lowers for easy turning of the work.

PUMP ELECTRICAL SPECIFICATIONS

APE Series – 3 hp, 460 volt, 60 cycles, three phase. Available in 220/380 volt, 50 cycle,

NOTE: To order press with a 230 volt, 60 cycles, single phase pump, order press less APE30. Order pump No. APE40 separately.

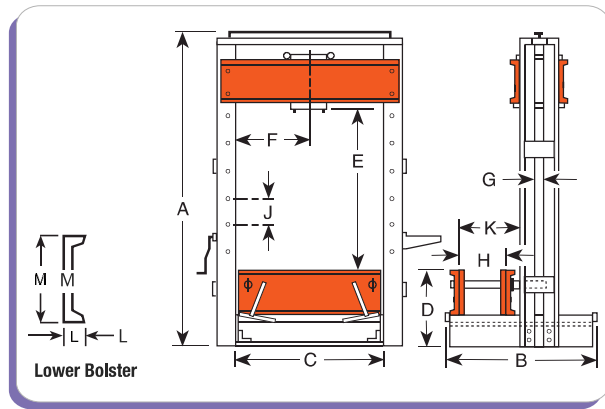

Cylinder is easily moved across width of upper bolster.

ROLL-BED PRESS
H Frame
80-200 Ton



Width adjust from 4" to over 27" is secured with locking bolts.



Lifting screw and locking pins make bolster raising a one-man job.



Bearings make bed positioning smooth and easy.



Lever lowers bed for pressing, raises it for rolling.

Capacity (Tons)	Type Cyl. Used	Stroke (mm)	Cyl. Model	ORDERING INFORMATION						
				Model No.	Speed Advance (mm)	Pressing (mm)	Type Pump	Valve Type	Pump Model	Prod. Wt. (kg)
80	Double-Acting	333	ARR-8013	ARB-8013S	1168	190	Elec.	4-way*	APE60S	1307
100	Double-Acting	333	ARR-10013	ARB-10013S	889	147	Elec.	4-way*	APE60S	1334
150	Double-Acting	333	ARR-15013	ARB-15013S	610	99	Elec.	4-way*	APE60S	2019
200	Double-Acting	333	ARR-20013	ARB-20013S	457	74	Elec.	4-way*	APE60S	2059

1. Solenoid valve with 24 volt remote control hand switch.
2. Frame is shipped assembled.
3. Pump standard with press. Other Aeroboom pumps can be substituted. DBA at idle and 10,000 psi. APE40M3N10G measured at 3 foot distance, all sides.
4. Typical performance based on 100 psi and 10000 psi pump specifications. Actual speeds may vary with operating conditions. 3,000 lbs maximum load can be sported on bed when raised on the rollers.

Cap. Tons	DIMENSIONS												
	A (mm)	B (mm)	C (mm)	D (mm)	E (mm)	F (mm)	G (mm)	H (mm)	J (mm)	K (mm)	L (mm)	M (mm)	Floor Space (mm)
80	2861	1632	1283	686	305-1524	368-914	76.2	102-692	203	927	86	381	1632 - 1537
100	2861	1632	1283	686	305-1524	368-914	76.2	102-692	203	927	86	381	1632 - 1537
150	3131	1734	1302	762	252-949	352-949	76.2	102-689	279	946	105	457	1734 - 1607
200	3131	1734	1302	762	252-949	352-949	76.2	102-689	279	946	105	457	1734 - 1607